

30" (76.2 CM) BUILT-IN ELECTRIC SINGLE AND
DOUBLE OVENS

30 PO (76,2 CM) FOURS ÉLECTRIQUES SIMPLES
ET DOUBLES, ENCASTRÉS

Use & Care Guide

For questions about features, operation/performance, parts, accessories, or service in the U.S.A., call:
1-800-JENNAIR (1-800-536-6247) or visit our website at www.jennair.com.
In Canada, call: **1-800-JENNAIR (1-800-536-6247)** or visit our website at www.jennair.ca.

Guide d'utilisation et d'entretien

Pour des questions à propos des caractéristiques, du fonctionnement/rendement, des pièces, accessoires ou dépannage, composer le :
1 800 JENNAIR (1 800 536-6247) ou visiter notre site Web au www.jennair.com.
Au Canada, composer le : **1 800 JENNAIR (1 800 536-6247)** ou visiter notre site Web au www.jennair.ca.



TABLE OF CONTENTS

BUILT-IN OVEN SAFETY	3
PARTS AND FEATURES	4
FEATURE GUIDE	5
Touch Panel	6
Display	6
Display Navigation	6
Menu Demonstrations	6
Kitchen Timer	8
Tones/Sounds	8
Tools	8
Button Lock	8
Oven Temperature Control	9
Sabbath Mode	9
OVEN USE	10
Wi-Fi Connectivity	10
Aluminum Foil	10
Position Racks and Bakeware	10
Roll-Out Extension Rack	11
Bakeware	12
Oven Vents	12
Preheating and Oven Temperature	12
Baking and Roasting	13
Broiling	13
Convection	13
Convection Bake	13
Convection Roast	14
Convection Broil	14
Convert Recipe	14
Proofing Bread	14
Temperature Probe	14
My Creations	15
Timed Cooking	16
Culinary Center	17
OVEN CARE	18
Self-Cleaning Cycle	18
General Cleaning	18
Oven Lights	19
Oven Door	19
TROUBLESHOOTING	20
ASSISTANCE OR SERVICE	21
In the U.S.A.	21
In Canada	21
Accessories	21

TABLE DES MATIÈRES

SÉCURITÉ DU FOUR ENCASTRÉ	22
PIÈCES ET CARACTÉRISTIQUES	23
GUIDE DES CARACTÉRISTIQUES	24
Panneau tactile	25
Affichage	25
Affichage du menu	25
Démonstration de menu	25
Minuterie de cuisine	27
Tons/Sons	27
Tools (outils)	27
Verrouillage des commandes	28
Commande de la température du four	28
Mode Sabbat	29
UTILISATION AU FOUR	30
Connexion Wi-Fi	30
Papier d'aluminium	30
Position des grilles et des ustensiles de cuisson au four	30
Grille coulissante déployante	31
Ustensiles de cuisson	32
Événements du four	32
Préchauffage et température du four	32
Cuisson au four et rôtissage	33
Cuisson au gril	33
Convection	33
Cuisson au four par convection	33
Rôtissage par convection	34
Cuisson au gril par convection	34
Convertir la recette	34
Levée du pain	34
Sonde thermométrique	34
Mes créations	35
Cuisson minutée	36
Centre culinaire	37
ENTRETIEN DU FOUR	38
Programme d'autonettoyage	38
Nettoyage général	39
Lampes du four	39
Porte du four	39
DÉPANNAGE	40
ASSISTANCE OU SERVICE	42
Au Canada	42
Accessoires	42

BUILT-IN OVEN SAFETY

Your safety and the safety of others are very important.

We have provided many important safety messages in this manual and on your appliance. Always read and obey all safety messages.



This is the safety alert symbol.

This symbol alerts you to potential hazards that can kill or hurt you and others.

All safety messages will follow the safety alert symbol and either the word “DANGER” or “WARNING.”

These words mean:

⚠ DANGER

You can be killed or seriously injured if you don't immediately follow instructions.

⚠ WARNING

You can be killed or seriously injured if you don't follow instructions.

All safety messages will tell you what the potential hazard is, tell you how to reduce the chance of injury, and tell you what can happen if the instructions are not followed.

IMPORTANT SAFETY INSTRUCTIONS

WARNING: To reduce the risk of fire, electrical shock, injury to persons, or damage when using the oven, follow basic precautions, including the following:

- Proper Installation – Be sure the oven is properly installed and grounded by a qualified technician.
- Never Use the Oven for Warming or Heating the Room.
- Do Not Leave Children Alone – Children should not be left alone or unattended in area where oven is in use. They should never be allowed to sit or stand on any part of the oven.
- Wear Proper Apparel – Loose-fitting or hanging garments should never be worn while using the oven.
- User Servicing – Do not repair or replace any part of the oven unless specifically recommended in the manual. All other servicing should be referred to a qualified technician.
- Storage in Oven – Flammable materials should not be stored in an oven.
- Do Not Use Water on Grease Fires – Smother fire or flame or use dry chemical or foam-type extinguisher.
- Use Only Dry Potholders – Moist or damp potholders on hot surfaces may result in burns from steam. Do not let potholder touch hot heating elements. Do not use a towel or other bulky cloth.
- Use Care When Opening Door – Let hot air or steam escape before removing or replacing food.
- Do Not Heat Unopened Food Containers – Build-up of pressure may cause container to burst and result in injury.

- Keep Oven Vent Ducts Unobstructed.
- Placement of Oven Racks – Always place oven racks in desired location while oven is cool. If rack must be moved while oven is hot, do not let potholder contact hot heating element in oven.
- DO NOT TOUCH HEATING ELEMENTS OR INTERIOR SURFACES OF OVEN – Heating elements may be hot even though they are dark in color. Interior surfaces of an oven become hot enough to cause burns. During and after use, do not touch, or let clothing or other flammable materials contact heating elements or interior surfaces of oven until they have had sufficient time to cool. Other surfaces of the oven may become hot enough to cause burns – among these surfaces are oven vent openings and surfaces near these openings, oven doors, and windows of oven doors.

For self-cleaning ovens:

- Do Not Clean Gasket – The gasket is essential for a good seal. Care should be taken not to rub, damage, or move the gasket.
- Do Not Use Oven Cleaners – No commercial oven cleaner or oven liner protective coating of any kind should be used in or around any part of the oven.
- Clean Only Parts Listed in Manual.
- Before Self-Cleaning the Oven – Remove broiler pan and other utensils.

For smart enabled ovens:

- Remote Operation – This appliance is configurable to allow remote operation at any time. Do not store any flammable materials or temperature sensitive items inside of the appliance.

SAVE THESE INSTRUCTIONS

PARTS AND FEATURES

This manual covers several models. Your model may have some or all of the items listed. Refer to this manual or the Frequently Asked Questions (FAQs) section of our website at www.jennair.com for more detailed instructions. In Canada, refer to the Customer Service Section at www.jennair.ca.

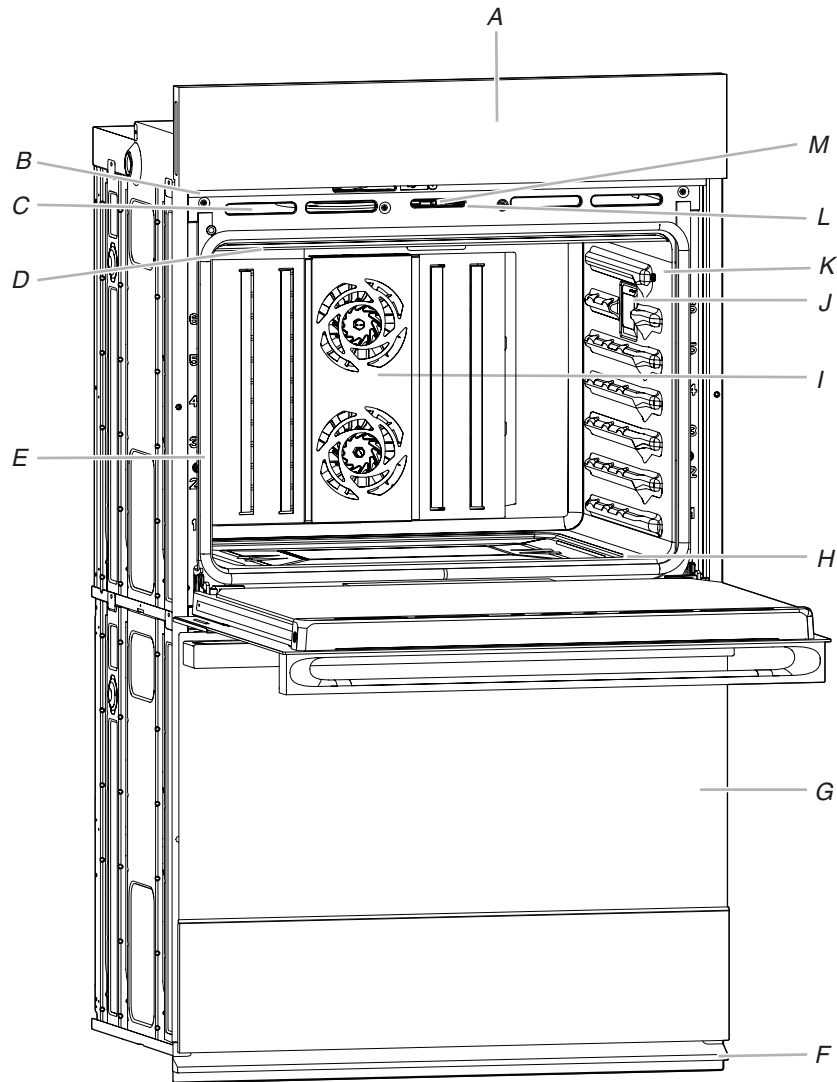

- A. Electronic oven control
- B. Model and serial number plate
(on right-hand side underneath the control panel)
- C. Oven vent
- D. Broil elements
- E. Gasket
- F. Bottom vent

- G. Lower oven (on double-oven models)
- H. Hidden bake element
- I. Twin convection elements and fans
- J. Oven lights (left side, not shown)
- K. Temperature probe jack
- L. Oven door lock latch
- M. Oven light switch

Parts and Features not shown
 Temperature probe
 Racks

FEATURE GUIDE

This manual covers several models. Your model may have some or all of the items listed. Refer to this manual or the Frequently Asked Questions (FAQs) section of our website at www.jennair.com for more detailed instructions. In Canada, refer to the Customer Service Section at www.jennair.ca.

Single Oven:

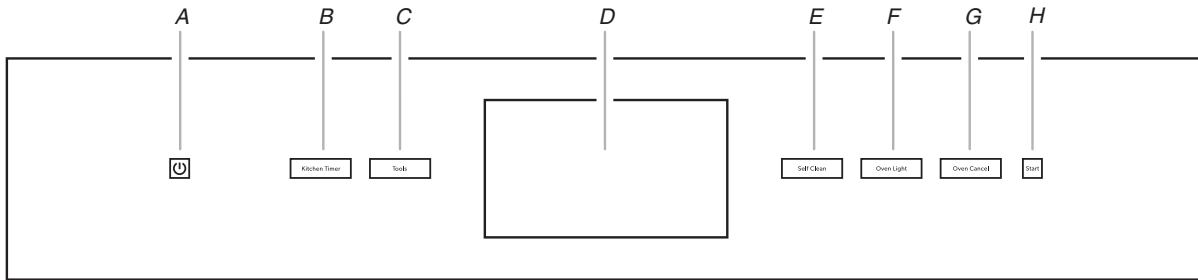

- A. Power
- B. Kitchen timer
- C. Tools
- D. Display
- E. Self clean
- F. Oven light
- G. Oven cancel
- H. Start

Double Oven:

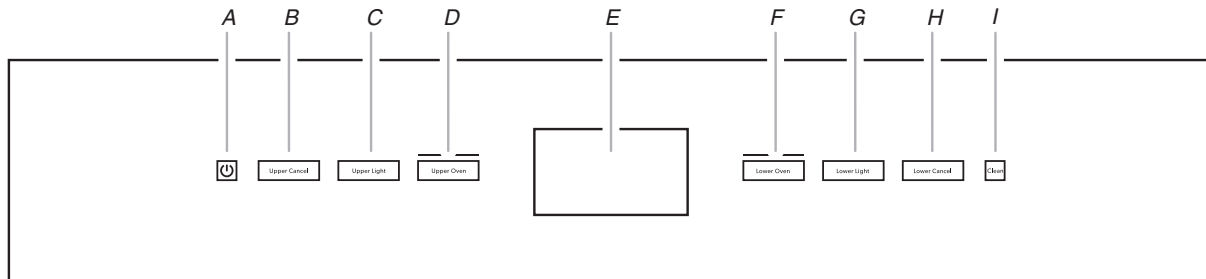

- A. Power
- B. Upper cancel
- C. Upper light
- D. Upper oven
- E. Display
- F. Lower oven
- G. Lower light
- H. Lower cancel
- I. Clean

Keypad	Feature	Instructions
POWER 	Power	Touch the Power keypad to turn the oven display on and off.
OVEN LIGHT UPPER LIGHT LOWER LIGHT	Oven cavity light	The desired oven light is controlled by a touch keypad on the oven control panel. While the oven door is closed, touch the desired Oven Light keypad to turn the oven lights on and off. When the oven door is opened, the oven lights will automatically come on for the corresponding oven.
KITCHEN TIMER (on some models)	Timer	The Kitchen Timer can be set in hours, minutes, or seconds up to 23 hours, 59 minutes, and 59 seconds. The Kitchen Timer does not start or stop the oven(s).
OVEN CANCEL UPPER CANCEL LOWER CANCEL (on some models)	Oven function	The Lower Cancel, Upper Cancel, and Cancel keypads stop their respective oven functions, except for the Clock, Kitchen Timer, and Button Lock. The oven cooling fan(s) may continue to operate even after an oven function has been canceled or completed, depending on the oven temperature.
START (on some models)	Mode Start	The Start keypad begins some oven functions. If Start is not touched within 2 minutes after touching a keypad, the function is canceled and the time of day is displayed.
CLEAN SELF CLEAN (on some models)	Self-Cleaning cycle	See the "Self-Cleaning Cycle" section.
TOOLS (on some models)	Oven use function	The Tools keypad enables you to personalize the oven operation to suit your needs. See the "Tools" section.
UPPER OVEN LOWER OVEN (on some models)	Oven selection	The Upper and Lower Oven keypads enable you to select which oven you want to use.

Touch Panel

The touch panel houses the control menu and function controls. The touch keypads are very sensitive and require only a light touch to activate.

For more information about the individual controls, see their respective sections in this manual.

Welcome Guide

This appears on your display the first time the oven is powered up. The Welcome Guide allows you to set up your new oven. After every selection, a tone will sound. Touch BACK at any time to return to the previous screen.

1. Select your language.
2. A new welcome screen will appear. Read it and touch NEXT.
3. Set the clock and AM, PM, or 24-hour clock (military time). Touch NEXT.
4. Select AUTO SYNC (turn on) or DO NOT ADJUST (turn off) to set the daylight savings time. Touch NEXT.
5. Set the current date. Touch NEXT.
6. Select FAHRENHEIT or CELSIUS to set the units of temperature. Touch NEXT.
7. Set the clock theme by selecting the desired theme. Touch NEXT, and then select the desired background. Touch SAVE.
NOTE: This is the background for the center touch display.
8. Select CONNECT to connect your appliance to Wi-Fi. Refer to the Wi-Fi connectivity manual for further information.

OR

Touch SKIP to skip this step and complete setup.

Display

The display is for both the menu and oven function controls. The touch panel allows you to scroll through the oven menus. The display is very sensitive and requires only a light touch to activate and control.

When an oven is in use, the display will show the clock, mode, oven temperature, kitchen timer, and oven timer, if set. If the oven timer is not set, you can set it from this screen.

After approximately 2 minutes of inactivity, the display will go into Sleep mode and the display will dim. When the oven is in operation, the display will remain bright.

During use, the display will show menus and the appropriate selections for the options being chosen.

Display Navigation

If the oven is off, touch the Power keypad to activate the menu. From the home screen, all automatic cooking programs can be activated, all manual cooking programs can be set, options can be adjusted, and instructions, preparation, and tips can be accessed.

Menu Demonstrations

WARNING

Food Poisoning Hazard

Do not let food sit in oven more than one hour before or after cooking.

Doing so can result in food poisoning or sickness.

In double-oven models, touch the corresponding oven keypad to show the cooking modes and temperatures for the desired oven.

NOTE: A line will appear above the corresponding oven keypad.

In single-oven models, the display will show cooking modes and temperatures when the oven is turned on.

Bake Demonstration

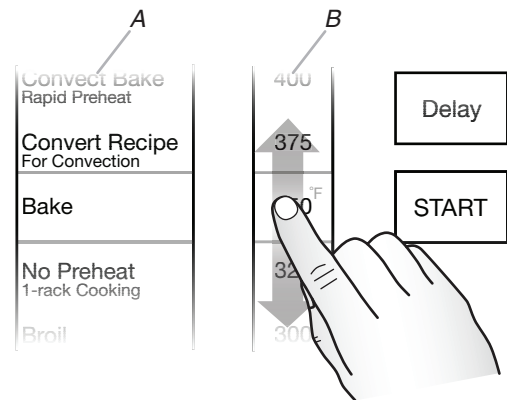

A. Modes column

B. Temperature column

1. In the Modes column, select BAKE.
2. In the Temperature column, select the desired temperature. The temperature must be between 170°F and 550°F (77°C and 288°C).
3. Touch START to begin preheating.

Drop-Down Message Demonstration

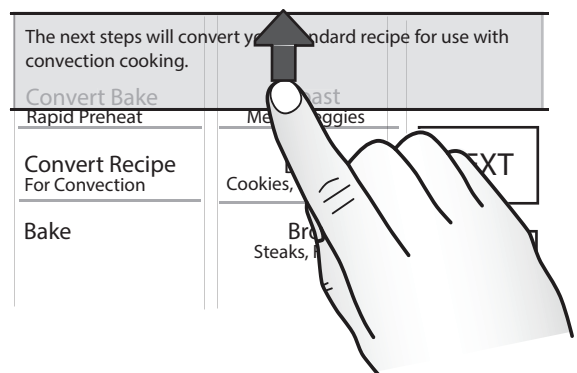

There are some menus that prompt a drop-down message to appear. Once the message is read, you can dismiss the menu by touching the directional arrow and swiping up.

Cook Time Demonstration (Optional)

NOTE: In some cooking modes, the user can set the cooking time while other modes have fixed times.

To set a cooking time, follow these instructions.

At any time, touch BACK to return to the previous screen. Touch CANCEL for the selected oven to cancel the current cycle and return to the main menu.

1. To set a cook time, first start a cooking cycle.

NOTE: The Oven Timer is only visible once a cooking cycle has been activated.

2. Touch OVEN TIMER. Set the cooking length.
3. Touch START to begin the Oven Timer.

OR

Select the desired "When Timer Ends" oven action, and then touch START. The default action is Hold Temp.

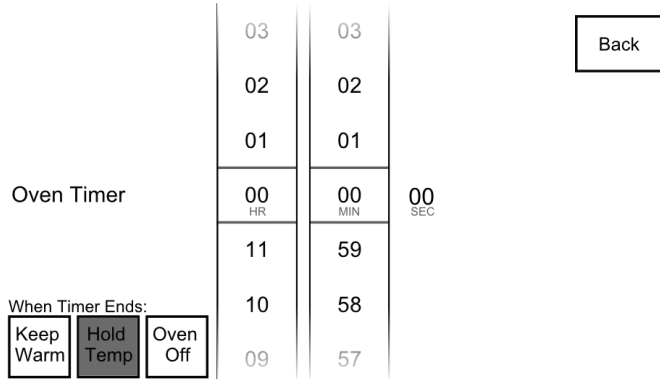

- Keep Warm will reduce the oven temperature to 170°F (77°C) after the cook time ends.
- Hold Temp will keep the set oven temperature after the cook time ends.
- Oven Off will turn the oven off when the cook time ends.

Delay Start Demonstration (Optional)

1. To set a delayed start and end time, select the desired cooking mode and temperature, and then touch DELAY.

NOTE: The cooking start time always begins on the nearest quarter hour (0:00, 0:15, 0:30, and 0:45). The cooking time includes the oven preheating time. Adjust the start and end times accordingly.

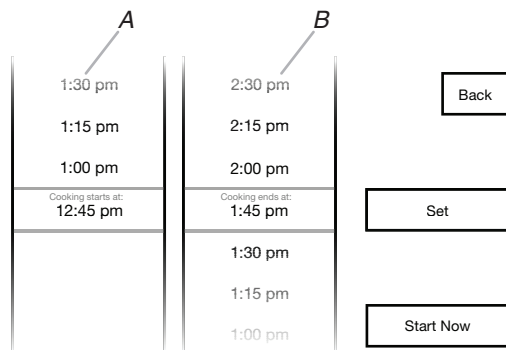

A. Start time column
B. End time column

2. Select the desired cooking start time in the Start Time column. The oven cannot be delayed more than 11 hours and 45 minutes.

3. Select the desired cooking end time in the End Time column. The cook time cannot be longer than 12 hours.

4. Touch SET when done, or touch BACK to return to the main menu.

The oven will start preheating when the start time is reached. Once the end time is reached, the oven will go into Keep Warm mode by default.

OR

Touch START NOW to start the oven from the Delay screen. This will set the Oven Timer but will not delay the start time.

NOTE: Do not use Delay Start for items that require a preheated oven, such as cakes, cookies, and breads. If food is in the oven during preheat, it may become overcooked.

5. To change a cooking mode or temperature while the oven is preheating or in a Delay Start, touch the Cooking Mode keypad, make the new selection, and then touch SET.
6. At any time, touch CANCEL for the selected oven to cancel the current cycle and return to the main menu.

Cooking Modes

The previous steps can be used for the following cooking modes:

Mode	Temp. Range	Default Temp.
Convect Frozen Pizza	300°F–500°F (149°C–260°C)	375°F (191°C)
Convect Pastry	170°F–550°F (77°C–288°C)	325°F (163°C)
Convect Slow Roast 12 hrs	190°F–225°F (88°C–107°C)	200°F (93°C)
Convect Slow Roast 8 hrs	200°F–250°F (93°C–121°C)	225°F (107°C)
Convect Slow Roast 4 hrs	250°F–300°F (121°C–149°C)	275°F (135°C)
True Convect	170°F–550°F (77°C–288°C)	325°F (163°C)
Convect Roast	170°F–550°F (77°C–288°C)	350°F (177°C)
Convect Broil	450°F–550°F (232°C–288°C)	550°F (288°C)
Convect Bake	170°F–550°F (77°C–288°C)	325°F (163°C)
Convect Bake – Rapid Preheat	170°F–550°F (77°C–288°C)	325°F (163°C)
Bake	170°F–550°F (77°C–288°C)	350°F (177°C)
No Preheat 1-Rack Cooking	170°F–550°F (77°C–288°C)	350°F (177°C)
Broil	450°F–550°F (232°C–288°C)	550°F (288°C)
Keep Warm	150°F–200°F (66°C–93°C)	170°F (77°C)
Rapid Proof	110°F (43°C)	110°F (43°C)
Proof	100°F (38°C)	100°F (38°C)

NOTE: To use Delay Start for Convert Recipe, Probe Cook, or My Creations, follow the on-screen prompts until the Delay keypad appears. The previous steps can then be used.

Kitchen Timer

The Kitchen Timer can be set in hours, minutes, and seconds and counts down the set time.

NOTE: The Kitchen Timer does not start or stop the oven.

Tones/Sounds

Tones are audible signals, indicating the following:

- Valid keypad touch.
- Function has been entered.
- Oven is preheated.
- Invalid keypad touch.
- End of a cooking cycle.
- When timer reaches zero.
- Includes using the Kitchen Timer for functions other than cooking.
- First oven element activation in a cooking mode.

Tools

The Tools keypad allows you access to functions and customization options within the Electronic Oven Control. These tools allow you to set the clock, change the oven temperature between Fahrenheit and Celsius, turn the audible signals and prompts on and off, adjust the oven calibration, change the language, and more. For more information on a setting, select it and touch the Tips keypad.

The Sabbath mode is also set using Tools.

Mode	Available Selections
Sabbath	<ul style="list-style-type: none">■ On■ Off (default)
Demo Mode	<ul style="list-style-type: none">■ On■ Off (default)
Temp Units	<ul style="list-style-type: none">■ Celsius*■ Fahrenheit*
Language	<ul style="list-style-type: none">■ Français*■ English*
Display On/Off	<ul style="list-style-type: none">■ Display Off■ Display Dimmed (default)
Clock On/Off	<ul style="list-style-type: none">■ Clock Off■ Clock On (default)
Brightness	<ul style="list-style-type: none">■ Max■ High■ Med (default)■ Low■ Dim
Sound	<ul style="list-style-type: none">■ Key Press (Max/High/Med (default)/Low/Off)■ Timer & Alert (Max/High (default)/Med/Low/Off)■ Power On & Off (Off/On (default))

Mode	Available Selections
Clock Theme	<ul style="list-style-type: none">■ Textures*■ Celebration*■ Culinary*■ Clock Only*■ Animation*■ Spring*■ Summer*■ Fall*■ Winter*
Time & Date	<ul style="list-style-type: none">■ Daylight Saving (Do not adjust/Auto Sync)*■ Clock Style (Digital/Analog (default))■ Set Clock■ Set Date
Wireless Features	<ul style="list-style-type: none">■ Enable Wi-Fi
Self Clean	<ul style="list-style-type: none">■ Heavy 5 hr■ Medium 4 hr (default)■ Light 3 hr
Button Lock	<ul style="list-style-type: none">■ Lock
Number Entry	<ul style="list-style-type: none">■ Number pad■ Scroll (default)
Probe	<ul style="list-style-type: none">■ Convect Roast■ Convect Bake■ Food Guide (default)■ Bake
Temp Calibration	<ul style="list-style-type: none">■ +35°F to -35°F■ +20°C to -20°C <p>NOTE: For double-oven models, upper and lower calibration are available.</p>
Touch Calibration	<ul style="list-style-type: none">■ Use to calibrate touch screen.
Service Info.	<ul style="list-style-type: none">■ Model Number, Serial Number, and contact information
Legal Info.	<ul style="list-style-type: none">■ License Information
Restore Defaults	<ul style="list-style-type: none">■ Restores Factory Defaults

*The default for these settings is set at the Welcome screen.

Button Lock

The Button Lock shuts down the control panel keypads to avoid unintended use of the oven(s). The Button Lock will remain set after a power failure if it was set before the power failure occurs. When the control is locked, only the Power keypad will function. The Button Lock is preset unlocked but can be locked.

To Activate the Button Lock:

1. Touch TOOLS, and then select BUTTON LOCK.
2. Touch LOCK to activate the Button Lock mode.

NOTE: The touch screen will return to Idle mode and a control locked message will be displayed.

To Deactivate the Button Lock:

1. Touch the Power keypad, and then follow the on-screen directions.

NOTE: The oven will generate a random sequence of shapes that must be touched in the order prompted on the screen.

Oven Temperature Control

IMPORTANT: Do not use a thermometer to measure the oven temperature. Elements will cycle on and off as needed to maintain a consistent temperature but may run slightly hot or cool at any point in time due to this cycling. Opening the oven door will affect cycling of the elements and impact the temperature.

The oven provides accurate temperatures and has been thoroughly tested at the factory. However, it may cook faster or slower than your previous oven, causing baking or browning differences. If necessary, the temperature calibration can be adjusted in either Fahrenheit or Celsius.

On double ovens, the upper oven and the lower oven can each be calibrated independently.

A minus sign means the oven will be cooler by the displayed amount. The absence of a minus sign means the oven will be warmer by the displayed amount. Use the following chart as a guide.

NOTE: The oven display will continue to show the original set temperature and will not reflect the calibration offset. For example, if set to 350° (177°C) and calibrated to -20°, the display will continue to show 350° (177°C).

Adjustment °F (Automatic °C Change)	Cooks Food
10°F (6°C)	a little more
20°F (12°C)	moderately more
30°F (18°C)	much more
0°F (0°C)	default setting
-10°F (-6°C)	a little less
-20°F (-12°C)	moderately less
-30°F (-18°C)	much less

Sabbath Mode

The Sabbath mode sets the oven(s) to remain on in a bake setting until turned off. A timed Sabbath mode can also be set to keep the oven on for only part of the Sabbath.

When the Sabbath mode is set, the allowed keypads are the Power keypad and the Cancel keypads.

When the oven door is opened or closed, the oven light will not turn on or off and the heating elements will not turn on or off immediately.

If a power failure less than 1 second occurs when the Sabbath mode is set, the oven(s) will remain in Sabbath mode and continue cooking.

For a power failure that lasts longer than a second, the oven(s) will return to an idle state and Sabbath mode will no longer be active. For double ovens, the upper and lower oven temperatures and cook timers can be set independently. If a cook timer is set, the countdown will not appear. The timer will appear frozen at the set time.

NOTE: Be sure to turn off your smart phone before the Sabbath or holidays. If the phone is on and the oven control app installed, oven changes will be displayed on your phone.

To Enable:

1. Touch the Power keypad, and then touch TOOLS.
2. Select SABBATH, and then touch NEXT.
3. Touch ON, and then touch SETUP.

NOTE: The programmed status of the oven(s) will be displayed.

4. Touch CHANGE.
5. For single ovens, go to Step 6. For double ovens, select the desired oven and then touch NEXT.

6. Select the desired oven temperature and touch NEXT.
(Optional) Set Bake Time (00:00) and touch SET.

OR

Touch SKIP TIMER.

7. For single ovens, touch START. For double ovens, touch START to begin Sabbath mode or touch CHANGE to edit the current programming or to program the other oven.

To Disable:

Once activated, Sabbath mode can be deactivated on all cavities by touching the Power keypad.

For single ovens, Sabbath mode can also be deactivated by touching OVEN CANCEL.

For double ovens, if both ovens are running, touching CANCEL for one oven will turn off Sabbath mode for both ovens and will turn off the selected oven. The other oven will return to a regular Bake mode.

Delayed Sabbath Bake:

⚠ WARNING

Food Poisoning Hazard

Do not let food sit in oven more than one hour before or after cooking.

Doing so can result in food poisoning or sickness.

For double ovens, the upper and lower oven temperatures and cook timers can be set independently.

If a cook timer is set, the countdown will not appear. The timer will appear frozen at the set time.

To Enable:

1. Touch the Power keypad, and then touch TOOLS.
2. Select SABBATH, and then touch NEXT.
3. Touch ON, and then touch SETUP.

NOTE: The programmed status of the oven(s) will be displayed.

4. Touch CHANGE.
5. For single ovens, go to Step 6. For double ovens, select the desired oven, and then touch NEXT.
6. Select the desired oven temperature, and then touch NEXT.
Optional: Set Bake Time (00:00) and touch SET.

OR

Touch SKIP TIMER.

7. Touch DELAY and set the "Cooking Starts at" and "Cooking Ends at" times.

NOTE: If a bake time is set in the previous steps, the "Cooking Ends at" will be calculated based on the bake time. If the timer is not set, the Sabbath mode will continue until canceled.

8. Touch SET.

Once activated, Sabbath mode can be deactivated on all cavities by touching the Power keypad.

Change Temperature

The oven temperatures can be changed while running Sabbath mode by touching the -25°F (-5°C) or +25°F (+5°C). Touching these buttons will not result in any changes to the screen and no sound will play.

As an example, touching the +25°F (+5°C) button 3 times will result in an oven cavity temperature increase of +75°F (+15°C); however, the initial oven cavity set temperature will remain on the screen.

NOTE: On double-oven models, the oven cavity temperature may be set independently.

OVEN USE

Odors and smoke are normal when the oven is used the first few times or when it is heavily soiled.

During oven use, the heating elements will not remain on but will cycle on and off throughout oven operation.

IMPORTANT: The health of some birds is extremely sensitive to the fumes given off. Exposure to the fumes may result in death to certain birds. Always move birds to another closed and well-ventilated room.

If the oven door is opened during a cooking mode and left open for approximately 60 seconds, the cooling fan will switch to a higher speed. You may experience higher noise during this time. When the oven door is closed, the fan will switch back to its lower speed after approximately 60 seconds.

Wi-Fi Connectivity

⚠ WARNING

Food Poisoning Hazard

Do not let food sit in oven more than one hour before or after cooking.

Doing so can result in food poisoning or sickness.

Your oven has built-in Wi-Fi connectivity. For it to work, you will have to help it join your home wireless network. For information about setting up the connectivity, turning it on and off, receiving important notifications, and taking advantage of available features, refer to the Oven Wi-Fi Connected Quick Start Guide that came with your appliance.

Once the setup process has been completed for the Wi-Fi, you will have access to features that will give you new freedom in cooking. Your available features may vary depending on firmware updates.

Viewing

- Cooking Timers
- Control Lock
- Kitchen Timers
- Meat Probe Status
- Remote Start Status

Control

- Turn Oven Off
- Adjust Kitchen Timer
- Adjust Oven Light
- Oven Control Lock
- Start Oven Controls
- Adjust Cooking Settings
- Culinary Center
- My Creations

Remote Notifications

Once the Wi-Fi connectivity has been established, you have the ability to receive status notifications via email and SMS/text. The notifications that can be received are:

- Oven Cycle Interruptions
- Preheat Complete
- Cook Timer Completion
- Cooking Temperature Change
- Pre-Heat Cooking Temperature Progress
- Meat Probe Temperature Change
- Meat Probe Temperature Reached
- Cooking Mode Change
- Control Lock Status Change
- Kitchen Timer Complete
- Kitchen Timer Change
- Self-Clean Complete
- Culinary Center Interruptions

Aluminum Foil

IMPORTANT: To avoid permanent damage to the oven bottom finish, do not line the oven bottom with any type of foil or liner.

- For best cooking results, do not cover entire rack with foil because air must be able to move freely.
- To catch spills, place foil on rack below dish. Make sure foil is at least 1/2" (13 mm) larger than the dish and that it is turned up at the edges.

Position Racks and Bakeware

IMPORTANT: To avoid permanent damage to the porcelain finish, do not place food or bakeware directly on the oven door or bottom.

Racks

- Position racks before turning on the oven.
- Do not position racks with bakeware on them.
- Make sure racks are level.

To move a rack, pull it out to the stop position, raise the front edge, and lift out. Use the following illustration and charts as guides.

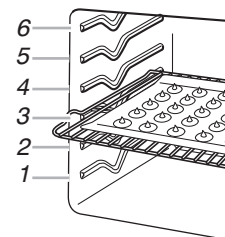

Rack And Bakeware Positions

Rack Positions – Upper and Lower Oven

Broiling

Food	Rack Position
Most broiling	6

For hamburger patties to have a well-seared exterior and a rare interior, use a flat rack in position 6. Side one should cook for approximately 3 minutes. Side two should cook for approximately 3 to 4 minutes. Expect a moderate degree of smoke when broiling.

Traditional Cooking

Food	Rack Position
Large roasts, turkeys, angel food cakes, bundt cakes, quick breads, pies	1 or 2
Yeast breads, casseroles, meat, poultry	2
Cookies, biscuits, muffins, cakes	2 or 3 when single-rack baking; 2 and 5 when multi-rack baking

Convection Cooking

Oven Setting	Number of Racks Used	Rack Position(s)
Rapid Preheat Bake	1 or 2	3
Rapid Preheat Convection Bake	1	3
Convection Bake	1	1, 2, or 3
Convection Bake	2	2 and 5
Convection Bake	3	1, 3, and 5
Convection Roast	1	1 or 2
Convection Broil	1	4, 5, or 6

Baking Cakes on Two Racks

For best results when baking cakes on two racks, use the Bake function and racks in positions 2 and 5. Place the cakes on the racks as shown. Keep at least 2" (5 cm) of space between the front of the racks and the front of the cakes.

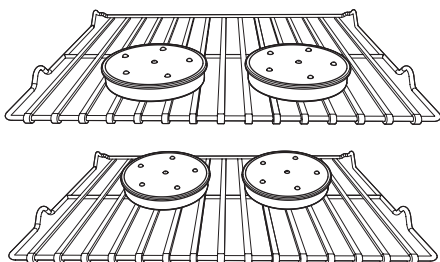

Baking Cookies on Two Racks

For best results when baking cookies on two racks, use the Convection Bake function and place flat racks in positions 2 and 5.

Bakeware

To cook food evenly, hot air must be able to circulate. For best results, allow 2" (5 cm) of space around bakeware and oven walls. Use the following chart as a guide.

Number of Pan(s)	Position on Rack
1	Center of rack
2	Side by side or slightly staggered
3 or 4	See the rack position graphics in this section for pan placement recommendations.

Roll-Out Extension Rack

The roll-out extension rack allows easy access to position food in the oven and remove food from the oven. It can be used in rack positions 1 through 6.

Open Position

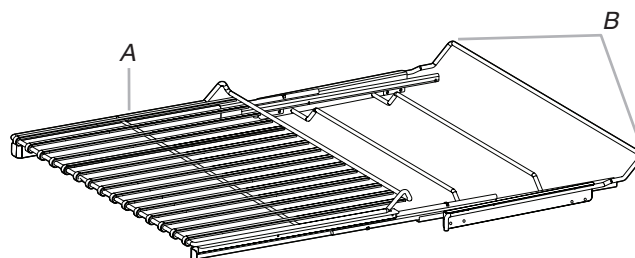

A. Roll-out extension rack
B. Sliding shelf

Closed and Engaged Position

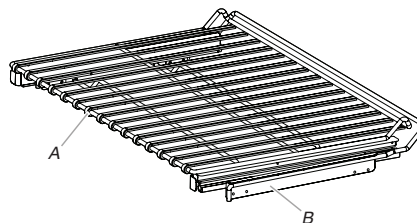

A. Roll-out extension rack
B. Sliding shelf

To Remove Roll-Out Extension Rack:

1. Slide the rack in completely so that it is closed and engaged with the sliding shelf.
2. Using two hands, lift up on the front edge of the rack and push the sliding shelf to the back wall of the oven so that the front edge of the sliding shelf sits on the rack guides. The front edge of the rack and the sliding shelf should be higher than the back edge.

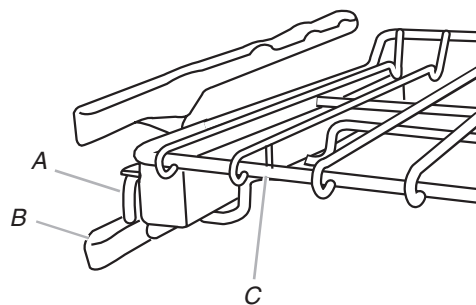

A. Sliding shelf
B. Rack guide
C. Roll-out extension rack

3. Pull the rack and the sliding shelf out.

To Replace Roll-Out Extension Rack:

- Using two hands, grasp the front of the closed rack and the sliding shelf. Place the closed rack and the sliding shelf on the rack guide.
- Using two hands, lift up on the front edge of the rack and the sliding shelf together.
- Slowly push the rack and the sliding shelf to the back of the oven until the back edge of the rack pulls over the end of the rack guide.

To avoid damage to the sliding shelves, do not place more than 25 lbs (11.4 kg) on the rack.

Do not clean the roll-out extension rack in a dishwasher. It may remove the rack's lubricant and affect its ability to slide.

See the "General Cleaning" section for more information.

Bakeware

The bakeware material affects cooking results. Follow manufacturer's recommendations and use the bakeware size recommended in the recipe. Use the following chart as a guide.

Bakeware/Results	Recommendations
Light-colored aluminum <ul style="list-style-type: none"> Light golden crusts Even browning 	<ul style="list-style-type: none"> Use temperature and time recommended in recipe.
Dark aluminum and other bakeware with dark, dull, and/or nonstick finish <ul style="list-style-type: none"> Brown, crisp crusts 	<ul style="list-style-type: none"> May need to reduce baking temperatures slightly. Use suggested baking time. For pies, breads, and casseroles, use temperature recommended in recipe. Place rack in center of oven.
Insulated cookie sheets or baking pans <ul style="list-style-type: none"> Little or no bottom browning 	<ul style="list-style-type: none"> Follow rack recommendations in the "Position Racks and Bakeware" section. May need to increase baking time.
Stainless steel <ul style="list-style-type: none"> Light, golden crusts Uneven browning 	<ul style="list-style-type: none"> May need to increase baking time.
Stoneware/Baking stone <ul style="list-style-type: none"> Crisp crusts 	<ul style="list-style-type: none"> Follow manufacturer's instructions.
Ovenproof glassware, ceramic glass, or ceramic <ul style="list-style-type: none"> Brown, crisp crusts 	<ul style="list-style-type: none"> May need to reduce baking temperatures slightly.

Oven Vents

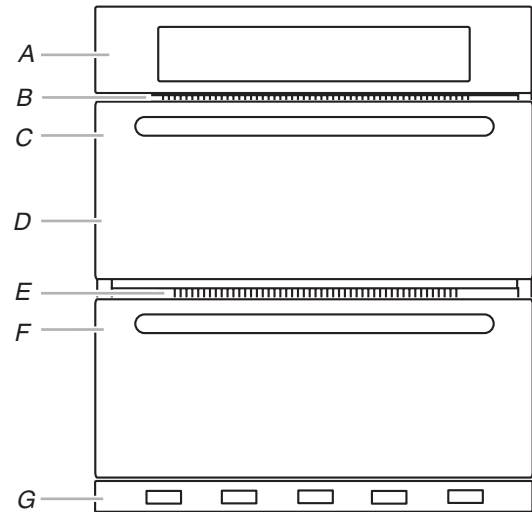

Single and Double Oven

- A. Control panel
- B. Oven vent
- C. Single oven or upper double oven
- G. Bottom vent

Double Oven

- D. Upper oven
- E. Oven vent
- F. Lower oven

The oven vents should not be blocked or covered since they allow the inlet of fresh air into the cooling system. Also, the bottom vent should not be blocked or covered since it allows the inlet of fresh air into the cooling system and the outlet of hot air from the cooling system. Blocking or covering vents will cause poor air circulation, affecting cooking, cleaning, and cooling results.

Preheating and Oven Temperature

Preheating

When beginning a Bake or Convect Bake cycle, the oven begins preheating after Start is pressed. The oven will take approximately 12 to 18 minutes to reach 350°F (177°C) with all of the oven racks provided with your oven inside the oven cavity. Higher temperatures will take longer to preheat. The preheat cycle rapidly increases the oven temperature. The actual oven temperature will go above your set temperature to offset the heat lost when your oven door is opened to insert food. This ensures that when you place your food in the oven, the oven will begin at the proper temperature. Insert your food when the preheat tone sounds. Do not open the door during preheat until the tone sounds.

NOTE: If the cook timer is set and the oven door is opened during preheating, the timer will automatically start.

Oven Temperature

While in use, the oven elements will cycle on and off as needed to maintain a consistent temperature. They may run slightly hot or cool at any point in time due to this cycling. Opening the oven door while in use will release the hot air and cool the oven which could impact the cooking time and performance. It is recommended to use the oven light to monitor cooking progress.

Baking and Roasting

IMPORTANT: The convection fan and convection element may operate during the Bake function to enhance performance and heat distribution.

The oven will take approximately 12 to 18 minutes to reach 350°F (177°C) with all oven racks inside the oven cavity. The preheat cycle rapidly increases the temperature inside the oven cavity. Higher temperatures will take longer to preheat. Factors that impact preheat times include room temperature, oven temperature, and the number of racks. Unused oven racks can be removed prior to preheating your oven to help reduce preheat time. The actual oven temperature will go above the set temperature to offset the heat lost when the oven door is opened to insert food. This ensures that the oven will begin at the proper temperature when you place food in the oven. Insert food when the preheat tone sounds. Do not open the door during preheat until the tone sounds.

During baking or roasting, the bake and broil elements will cycle on and off in intervals to maintain the oven temperature.

Depending on the model, if the oven door is opened during baking or roasting, the heating elements (bake and broil) will turn off approximately 30 seconds after the door is opened. They will turn on again approximately 30 seconds after the door is closed.

Broiling

Broiling uses direct radiant heat to cook food.

The element cycles on and off in intervals to maintain the oven temperature.

NOTE: No preheating is required for the Broiling function.

IMPORTANT: Close the door to ensure proper broiling temperature.

If the oven door is opened during broiling, the broil element will turn off in approximately 30 seconds. When the oven door is closed, the element will come back on approximately 30 seconds later.

- For best results, use a broiler pan and grid. It is designed to drain juices and help avoid spatter and smoke.
- For proper draining, do not cover the grid with foil. The bottom of the broiler pan may be lined with aluminum foil for easier cleaning.
- Trim excess fat to reduce spattering. Slit the remaining fat on the edges to avoid curling.
- Pull out oven rack to stop position before turning or removing food. Use tongs to turn food to avoid the loss of juices. Very thin cuts of fish, poultry, or meat may not need to be turned.
- After broiling, remove the pan from the oven when removing the food. Drippings will bake on the pan if left in the heated oven, making cleaning more difficult.

Convection

In a convection oven, the fan-circulated hot air distributes heat more evenly. This movement of hot air helps maintain a consistent temperature throughout the oven, cooking foods more evenly while sealing in moisture.

Most foods, using convection baking mode, can be cooked by lowering cooking temperatures 25°F (14°C). The cooking time can be shortened significantly when using Convection Roast, especially for large turkeys and roasts.

- It is important not to cover foods with lids or aluminum foil so that surface areas remain exposed to the circulating air, allowing browning and crisping.
- Keep heat loss to a minimum by opening the oven door only when necessary. It is recommended to use the oven light to monitor progress.
- Choose cookie sheets without sides and roasting pans with lower sides to allow air to move freely around the food.
- Test baked goods for doneness a few minutes before the minimum cooking time using a method such as a toothpick.
- Use a meat thermometer or the temperature probe to determine the doneness of meats and poultry. Check the temperature of pork and poultry in two or three places.

Convection Bake

The convection element is hidden in the rear panel of the oven cavity and, assisted by the convection fan, provides balanced, efficient heating.

Convection baking can be used for baking delicate cakes and pastries as well as foods on multiple racks. It is helpful to stagger items on the racks to allow a more even flow of heat. If the oven is full, extra cooking time may be needed.

When cooking an oven meal with several different types of foods, be sure to select recipes that require similar temperatures. Cookware should sit in the oven with at least 2" (5 cm) of space between the cookware and the sides of the oven.

During convection baking preheat, the convection, bake, and broil elements all heat the oven cavity. After preheat, these elements will cycle on and off in intervals to maintain oven temperature while the fan circulates the hot air.

If the oven door is opened during convection baking, the fan turns off immediately and turns on as soon as the door is closed. Convection, bake, and broil elements will turn off approximately 30 seconds after the door is opened. They will turn on again approximately 30 seconds after the door is closed.

NOTE: It is normal for the convection fan to run during non-convection cycles as well as during preheat.

- Reduce recipe temperature 25°F (14°C). The cook time may need to be reduced also.

To Convection Bake:

Before convection baking, position racks according to the "Positioning Racks and Bakeware" section.

Convection Roast

Convection roasting can be used for roasting meats and poultry. During convection roasting, the bake, broil, and convection elements will cycle on and off in intervals to maintain oven temperature while the fan circulates the hot air.

If the oven door is opened during convection roasting, the fan turns off immediately and turns on as soon as the door is closed. The bake, broil, and convection elements will turn off approximately 30 seconds after the door is opened. They will turn on again approximately 30 seconds after the door is closed.

NOTE: It is normal for the convection fan to run during non-convection cycles as well as during preheat.

To Convection Roast:

Before convection roasting, position racks according to the “Positioning Racks and Bakeware” section. It is not necessary to wait for the oven to preheat before putting food in, unless recommended in the recipe.

Convection Broil

During convection broiling, the broil element will cycle on and off in intervals to maintain oven temperature while the fan circulates the hot air.

The temperature is preset at 550°F (288°C) but can be changed to a different temperature. Cooking times will vary depending on the rack position and temperature, and may need to be adjusted.

If the oven door is opened during convection broiling, the fan turns off immediately and turns on as soon as the door is closed. Broil elements will turn off approximately 30 seconds after the door is opened. They will turn on again approximately 30 seconds after the door is closed.

NOTE: It is normal for the convection fan to run during non-convection cycles as well as during preheat.

To Convection Broil:

For ideal performance, allow the oven to preheat for 5 minutes (no preheat tone will sound). Position food on the unheated grid on the broiler pan, and then place it in the center of the oven rack with the longest side parallel to the door.

Convert Recipe

1. If preheat is not required, place food in oven and close the door.
2. Touch the Power keypad.
3. Select CONVERT RECIPE (FOR CONVECTION).
4. Select PASTRY, ROAST, BAKE, or BROIL to convert a traditional recipe to a convection method of cooking.
5. Touch NEXT.
6. Select the standard cooking temperature.
7. Touch NEXT.
8. Select the original recipe Bake/Roast/Broil time and touch SET.

OR

Touch SKIP TIMER to move to the next step.

9. Touch START. If preheat is required, place food in oven after preheat tone sounds. The display will count down the cook time. When the stop time is reached, the oven will display “TIMER ENDED AT XX:XX” (the time of day) and transition to hold temperature, which maintains the oven temperature. If enabled, end-of-cycle tones will sound.

NOTE: Touch DELAY to delay the baking cycle. Refer to the “Timed Cooking” section for setting delayed start and end times.

10. At any time, touch CANCEL for the selected oven to cancel the current cycle and return to the main menu.

Proofing Bread

Proofing bread prepares dough for baking by activating the yeast. Proofing twice is recommended unless the recipe directs otherwise.

To Proof:

For best performance, ensure your oven cavity temperature is below 120°F (49°C) before placing dough in oven cavity. Before first proofing, place dough in a lightly greased bowl and cover loosely with plastic wrap coated with shortening or cooking spray. Place on a rack in rack position 2. See the “Positioning Racks and Bakeware” for diagram. Close door.

1. Select PROOF. The display will show 100°F (38°C).
2. Touch START.

Let dough rise until nearly doubled in size. Check at 20 to 25 minutes. Proofing time may vary depending on dough type and quantity.

3. At any time, touch CANCEL for the selected oven to cancel the current cycle and return to the main menu.

Before second proofing, shape dough, place in baking pan(s), and cover loosely. Follow the same placement and control steps above. Before baking, remove waxed paper or plastic wrap.

Temperature Probe

The temperature probe accurately measures the internal temperature of meat, poultry, and casseroles with liquid and should be used in determining the doneness of meat and poultry. The temperature probe should only be used with Bake, Convection Bake, or Convection Roast.

Always unplug and remove the temperature probe from the oven when removing food.

Before using, insert the probe into the food item. For meats, the probe tip should be located in the center of the thickest part of the meat and not into the fat or touching a bone. Place food in oven and connect the temperature probe to the jack. Keep probe as far away from heat source as possible. Close oven door.

NOTE: The temperature probe must be inserted into the food item before the mode is selected.

To Use (Convection Roast, Convection Bake, or Bake):

1. Select PROBE COOK.
2. Select the desired cooking mode and touch NEXT.
3. Select the desired oven temperature and touch NEXT.
4. Select the desired food temperature and touch NEXT.
5. Read the Cooking Instructions.
6. Touch START.

OR

Touch DELAY to delay the baking cycle. Refer to the “Timed Cooking” section for setting delayed start and end times.

To Use: (Food Guide):

1. Select PROBE COOK.
2. Select FOOD GUIDE and touch NEXT.
3. Select the desired food category.
4. Select the desired doneness level or food type. Touch NEXT. See the following chart for doneness options.

Food Category	Doneness Options
Precooked Ham	N/A
Pork	<ul style="list-style-type: none"> ■ Medium ■ Well-Done
Chicken	<ul style="list-style-type: none"> ■ Breast ■ Whole
Turkey	<ul style="list-style-type: none"> ■ Breast ■ Whole
Beef	<ul style="list-style-type: none"> ■ Medium-Rare ■ Medium ■ Well-Done
Lamb	<ul style="list-style-type: none"> ■ Medium-Rare ■ Medium ■ Well-Done
Veal	<ul style="list-style-type: none"> ■ Medium-Rare ■ Medium ■ Well-Done

5. Select the original oven temperature. Touch NEXT.
6. Read the Cooking Instructions. Touch START to begin the cooking cycle.

NOTES:

- Depending on the probe attachment status, a tone may sound and the oven may instruct you to add or remove the probe.
- Touch DELAY to delay the baking cycle. Refer to the “Timed Cooking” section for setting delayed start and end times.

My Creations

My Creations allows the customization of cooking processes. When My Creations is selected from the main menu, a list of existing creations is presented along with the ability to create more.

To Create New Creation

1. Select MY CREATIONS.
2. Select CREATE NEW, USE SAVED, or DELETE/EDIT. Touch NEXT.
NOTE: The first time My Creations is used, only “Create New” will be displayed.
3. Select the desired cooking mode.
NOTE: My Creations cannot be used with Convert Recipe or Probe Cook.
4. Select the desired temperature. Touch NEXT.
5. Select how to monitor the cooking: Set Timer (alerts you when a cook timer is complete), Set Probe (alerts you when a target probe temperature is reached), or No Alerts. Touch NEXT.
NOTE: Probe can be used only for Bake, Convection Bake, or Convection Roast.
6. If No Alerts is chosen, go to Step 7.

OR

If Set Timer is chosen, set the desired time. Touch SET.

OR

If Set Probe is chosen, select the target probe internal temperature. Touch NEXT.

7. Review your settings. If any extra stage is needed, touch the stage you wish to set, and then touch ADD.
NOTE: Each stage set shows the following information: Mode, Power/Temperature, and Cook Time. It is possible to have 3 stages. If you wish to update any part of this, touch EDIT.
8. Enter the information into each stage, and then touch SAVE.
9. Name your creation by using the on-screen keypad. Touch SAVE.
10. Touch START to begin the baking cycle for your creation.

OR

Touch DELAY to delay the baking cycle. Refer to the “Timed Cooking” section for setting delayed start and end times.

To Use Saved Creation

1. Select MY CREATIONS.
2. Select USE SAVED, and then touch NEXT.
3. Select the desired cooking creation, and then touch START.
NOTE: You may be prompted to open and close the door before the creation can begin cooking.

To Delete Creation

1. Select MY CREATIONS.
2. Select DELETE/EDIT, and then touch NEXT.
3. Select the creation you wish to delete.
4. Touch DELETE.

To Edit Creation

1. Select MY CREATIONS.
2. Select DELETE/EDIT, and then touch NEXT.
3. Select the desired creation, and then touch EDIT.
4. Select the stage to be modified, and then touch EDIT.
NOTE: If a stage is empty, you can touch ADD to add an action to that stage.
5. Select the desired temperature. Touch NEXT.
6. Select how to monitor the cooking: Set Timer (alerts you when a cook timer is complete), Set Probe (alerts you when a target probe temperature is reached), or No Alerts. Touch NEXT.
NOTE: Probe can be used only for Bake, Convection Bake, or Convection Roast.
7. If No Alerts is chosen, go to Step 8.

OR

If Set Timer is chosen, set the desired time. Touch SET.

OR

If Set Probe is chosen, select the target probe internal temperature. Touch NEXT.

8. Review your settings. If any extra stage is needed, touch the stage you wish to set, and then touch ADD.
NOTE: Each stage set shows the following information: Mode, Power/Temperature, and Cook Time. It is possible to have three stages. If you wish to update any part of this, touch EDIT.
9. Enter the information into each stage, and then touch SAVE.
10. Name your creation by using the on-screen keypad. Touch SAVE.
11. Touch START to begin the baking cycle for your creation.

OR

Touch DELAY to delay the baking cycle. Refer to the “Timed Cooking” section for setting delayed start and end times.

Timed Cooking

WARNING

Food Poisoning Hazard

Do not let food sit in oven more than one hour before or after cooking.

Doing so can result in food poisoning or sickness.

Oven Timer and Delay Start allow the oven(s) to be set to turn on at a certain time of day, cook for a set length of time, and/or shut off automatically. Delay Start should not be used for food such as breads and cakes because they may not bake properly.

To Set an Oven Timer:

The Oven Timer will turn the selected oven off when the set time has expired. The maximum length is 11:59:00.

NOTE: In double-oven models, begin by selecting either Upper Oven or Lower Oven from the control panel.

1. Select the desired cooking mode and oven temperature, and then touch START.
2. Touch OVEN TIMER next to the displayed cooking mode and temperature.
3. Set the desired length of time for the Oven Timer.
4. Touch START.

OR

Touch one of the When Timer Ends keypads to set the behavior of the oven after the Oven Timer has completed. Choose between Hold Temp (default), Keep Warm, and Oven Off. Touch START.

- Keep Warm will reduce the oven temperature to 170°F (77°C) after the cook time ends.
- Hold Temp will keep the set oven temperature after the cook time ends.
- Oven Off will turn the oven off when the cook time ends.

When the Oven Timer has completed, the When Timer Ends behavior will begin and a message of “TIMER ENDED AT XX:XX” (the time of day) is displayed.

If enabled, end-of-cycle tones will sound, and then tones will sound every minute.

5. At any time, touch CANCEL for the selected oven to cancel the current cycle and return to the main menu, or open and close the oven door to clear the display and/or stop reminder tones.

To Cancel the Oven Timer only:

1. Touch the Oven Timer.
2. Touch OFF.

To Edit the Oven Timer:

1. Touch the Oven Timer.
2. Select the new desired length of time.
3. Touch SET.

To Set a Delay Start Time and Stop Time:

Before setting, make sure the clock is set to the correct time of day. For double ovens, be sure to select the desired oven before proceeding.

NOTE: In double-oven models, begin by selecting either Upper Oven or Lower Oven from the control panel.

1. Select the desired cooking mode and oven temperature. Follow the on-screen prompts until the Delay keypad appears.
NOTE: Delay Start may be used with the Bread Proof function, but the temperature is not adjustable.
2. Touch DELAY.
3. Set the desired “Cooking start at” time.
NOTE: The start and end times are rounded to the nearest quarter hour (00:00, 00:15, 00:30, or 00:45).
4. Set the desired “Cooking ends at” time.
5. Touch SET.

OR

Touch START NOW to immediately begin the cooking timer without a delay.

The difference between the “Cooking start at” time and the “Cooking ends at” time is used as the cooking timer.

When the start time is reached, the oven will automatically turn on. The time countdown will appear on the oven display.

When the Oven Timer has completed, the When Timer Ends behavior will begin and a message of “TIMER ENDED AT XX:XX” (the time of day) is displayed.

If enabled, end-of-cycle tones will sound, and then reminder tones will sound every minute.

6. Touch CANCEL for the selected oven to cancel the current cycle and return to the main menu.

If the oven door is opened and closed after the cycle ends, the display will be cleared and the reminded tones will stop, but the oven will continue to operate in the end-of-cycle behavior selected (Keep Warm is the default behavior).

NOTE: Changing the Oven Temperature or Oven Time after the Start Time is reached will change the When Timer Ends behavior to the Hold Temp function.

Culinary Center

The Culinary Center is full of information to assist in baking and cooking a wide variety of foods. As you program this mode, you will make selections such as type of meat, vegetable, preferred doneness level, browning level, and pan type, depending on the food. There are helpful tips and hints as you progress through the menu. The Culinary Center will make adjustments based on the doneness and pan you select. All of the selections cycle the appropriate elements and fans for the programmed food.

Cook all foods to minimum safe internal temperatures. Consuming raw or under-cooked meats, poultry, seafood, shellfish, or eggs may increase your risk of food-borne illness. Visit foodsafety.gov/keep/charts/mintemp.html for a complete listing.

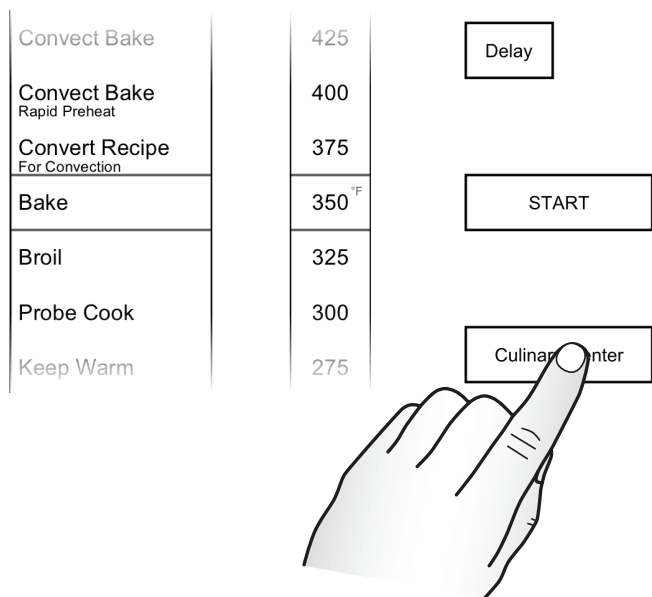

- From the main menu, touch CULINARY CENTER.
- Select the desired food category.
- Select the desired food type and touch NEXT.
- (For some foods) Select the Doneness level.
- Touch NEXT.
- Select the desired Cookware Type and touch NEXT.
- If the selected food type uses a probe cook method, skip to Step 8.

OR

If the selected food type uses a Timed Cook method, select the original temperature and touch NEXT.

- Select the original cook time and touch NEXT.
NOTE: The Time Range feature can be used at this point. This feature uses an average cook time based on the longest and shortest times entered.
- Read and follow the Cooking Tips to ensure optimum oven performance and touch START.

At any time, touch CANCEL for the selected oven to cancel the current cycle and return to the main menu.

NOTE: Depending on the Food Type selected and probe attachment status, a tone may sound and the oven may instruct you to add or remove the probe.

Culinary Center Modes

Food Category	Cook Method	Food Type
Vegetables	Probe Timed	Baked Potatoes Roasted Vegetables
Casseroles	Timed	Chicken Casserole Lasagna Sweet Potato Casserole Tuna Casserole
Baked Goods	Timed	Biscuits Bread Brownies Cake Cookies Cupcakes Pie Crust
Roasts	Probe	Beef Tenderloin Crown Lamb Roast Meat Loaf (Timed Cook also available) Prime Rib Round Roast
Poultry	Probe	Bone-in Chicken Boneless Chicken Chicken Roaster Duck Turkey
Pork	Probe	Ham Pork Loin
Seafood	Probe	Fish Fillet Salmon/Tuna Steak Swordfish Steak

OVEN CARE

Self-Cleaning Cycle

⚠ WARNING



Burn Hazard

Do not touch the oven during the Self-Cleaning cycle.

Keep children away from oven during Self-Cleaning cycle.

Failure to follow these instructions can result in burns.

IMPORTANT: The health of some birds is extremely sensitive to the fumes given off during the Self-Cleaning cycle. Exposure to the fumes may result in death to certain birds. Always move birds to another closed and well-ventilated room.

Self-clean the oven before it becomes heavily soiled. Heavy soil results in longer cleaning and more smoke.

Keep the kitchen well-ventilated during the Self-Cleaning cycle to help get rid of heat, odors, and smoke.

Do not block the oven vent(s) during the Self-Cleaning cycle. Air must be able to move freely. See the "Oven Vents" section.

Do not clean, rub, damage, or move the oven door gasket. The door gasket is essential for a good seal.

Prepare Oven:

- Remove the broiler pan, grid, cookware and bakeware, and, on some models, the temperature probe from the oven.
- Remove oven racks to keep them shiny and easy to slide. See the "General Cleaning" section for more information.
- Remove any foil from the oven because it may burn or melt, damaging the oven.
- Hand clean inside door edge and the 1 $\frac{1}{2}$ " (3.8 cm) area around the inside oven cavity frame, being certain not to move or bend the gasket. This area does not get hot enough during high-temp self-cleaning to remove soil. Do not let water, cleaner, etc., enter slots on door frame. Use a damp cloth to clean this area.
- Wipe out any loose soil to reduce smoke and avoid damage. At high temperatures, foods react with porcelain. Staining, etching, pitting, or faint white spots can result. This is normal and will not affect cooking performance.

How the Cycle Works

IMPORTANT: The heating and cooling of porcelain on steel in the oven may result in discoloring, loss of gloss, hairline cracks, and popping sounds.

The Self-Cleaning cycle uses very high temperatures, burning soil to a powdery ash.

Suggested clean times are 3 hours for light soil, 4 hours for medium soil, and 5 hours for heavy soil.

Once the oven has completely cooled, remove ash with a damp cloth. To avoid breaking the glass, do not apply a cool damp cloth to the inner door glass before it has completely cooled.

The oven lights will not work during the Self-Cleaning cycle.

NOTE: The oven has a 2-speed cooling fan motor. During the Self-Cleaning cycle, the fan(s) will operate at its highest speed to increase airflow to better exhaust the hotter air through the oven vent(s). An increase in noise may be noticeable during and after the Self-Cleaning cycle until the oven cools.

To Start Self-Cleaning Cycle:

Before Self-Cleaning, make sure the door is closed completely or it will not lock and the cycle will not begin.

1. For single ovens, touch SELF CLEAN. For double ovens, touch TOOLS, select SELF CLEAN, and then touch the desired oven to clean.
2. Select the desired time/soil level, and then touch NEXT.
3. Read the on-screen instructions, and then touch NEXT.
4. Follow the on-screen directions. The oven will prompt you to touch a series of keypads to confirm the Self-Cleaning cycle.

The oven will start locking the door. Opening the door at this point will cancel the Self-Cleaning cycle. The start time and stop time will appear on the oven display.

When the cycle is complete, a countdown timer will be displayed that represents the amount of time remaining before the door is unlocked. The door will not unlock until the oven is cool.

NOTE: The oven door will lock before the timer begins counting down.

If enabled, end-of-cycle tones will sound, and then reminder tones will sound every minute.

To Stop Self-Cleaning Anytime:

Touch CANCEL for the appropriate oven. If the oven temperature is too high, the door will remain locked. It will not unlock until the oven cools.

General Cleaning

IMPORTANT: Before cleaning, make sure all controls are OFF and the oven is cool. Always follow label instructions on cleaning products. For additional information, you can visit the Frequently Asked Questions (FAQs) section of our website at www.jennair.com. In Canada, reference the Customer Service section at www.jennair.ca.

Soap, water, and a soft cloth or sponge are suggested first unless otherwise noted.

STAINLESS STEEL (on some models)

To avoid damage to stainless steel surfaces, do not use soap-filled scouring pads, abrasive cleaners, Cooktop Cleaner, steel-wool pads, gritty washcloths, or abrasive paper towels.

Cleaning Method:

Rub in direction of grain to avoid damaging.

- Affresh® Stainless Steel Cleaner Part Number W10355016 (not included):
See the "Accessories" section for more information.

OVEN DOOR EXTERIOR

Cleaning Method:

- Glass cleaner and a soft cloth or sponge:
Apply glass cleaner to soft cloth or sponge, not directly on panel.
- Affresh® Kitchen and Appliance Cleaner Part Number W10355010 (not included):
See the "Accessories" section for more information.

OVEN DOOR INTERIOR

Cleaning Method:

- Self-Cleaning cycle:
For optimal door-cleaning results, wipe away any deposits with a damp sponge before running cycle.

CONTROL PANEL

To avoid damage to the control panel, do not use abrasive cleaners, steel-wool pads, gritty washcloths, or abrasive paper towels.

Cleaning Method:

- Glass cleaner and soft cloth or sponge:
Apply glass cleaner to soft cloth or sponge, not directly on panel.
- Affresh® Kitchen and Appliance Cleaner Part Number W10355010 (not included):
See the “Accessories” section for more information.

OVEN CAVITY

Do not use oven cleaners.

Food spills should be cleaned when oven cools. At high temperatures, foods react with porcelain. Staining, etching, pitting, or faint white spots can result.

Cleaning Method:

Self-Cleaning cycle:
See “Self-Cleaning Cycle” first.

OVEN RACKS

Cleaning Method:

- Steel-wool pad

Oven Lights

The oven lights are 120 V, 40 W maximum halogen bulbs. They will come on when the oven door is opened. On double oven models, both upper and lower lights will come on when either door is opened. The oven lights will not work during the Self-Cleaning cycle.

When the door is closed, touch the appropriate Oven Light keypad to turn on the oven light.

To Replace:

Before replacing the bulb, make sure the oven is off and cool.

1. Disconnect power.
2. Remove glass light cover by grasping the front edge and pulling away from oven.



3. Remove bulb from socket.
4. Replace bulb, using tissue or wearing cotton gloves to handle bulb. To avoid damage to or decreasing the life of the new bulb, do not touch bulb with bare fingers.
5. Replace bulb cover by snapping back into wall.
6. Reconnect power.

IMPORTANT: Do not use bulbs rated higher than 40 W.

Oven Door

IMPORTANT: To avoid oven door glass breakage:

- Do not close the oven door if the racks are not fully inserted into the oven cavity or when bakeware extends past the front edge of an oven rack.
- Do not set objects on the glass surface of the oven door.
- Do not hit glass surfaces with bakeware or other objects.
- Do not wipe down glass surfaces until the oven has completely cooled.

For normal oven use, it is not suggested to remove the oven door. However, if removal is necessary, make sure the oven is OFF and cool. Then, follow these instructions. The oven door is heavy.

To Remove:

1. Open oven door all the way.
2. Flip up the hinge latch on each side.

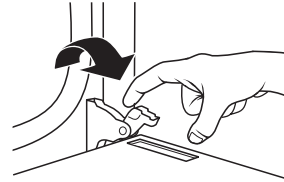

3. Close the oven door as far as it will shut.
4. Lift the oven door while holding both sides.
Continue to push the oven door closed and pull it away from the oven door frame.

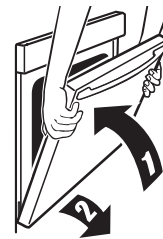

To Replace:

1. Insert both hanger arms into the door.



2. Open the oven door.
You should hear a “click” as the door is set into place.
3. Move the hinge levers back to the locked position. Check that the door is free to open and close. If it is not, repeat the removal and installation procedures.

TROUBLESHOOTING

First try the solutions suggested here. If you need further assistance or more recommendations that may help you avoid a service call, refer to the warranty, or visit producthelp.jennair.com. In Canada, visit www.jennair.ca.

Contact us by mail with any questions or concerns at the address below:

In the U.S.A.:

JennAir Brand Home Appliances
Customer eXperience Center
553 Benson Road
Benton Harbor, MI 49022-2692

In Canada:

JennAir Brand Home Appliances
Customer eXperience Centre
200 – 6750 Century Ave.
Mississauga, Ontario L5N 0B7

Please include a daytime phone number in your correspondence.

Problem	Possible Causes and/or Solutions
Nothing will operate	Has a household fuse blown or has a circuit breaker tripped? Replace the fuse or reset the circuit breaker. If the problem continues, call an electrician. Is the appliance wired properly? See Installation Instructions.
Oven will not operate	Has a Delay Start been set? See the “Timed Cooking” section. Is the Button Lock set? See the “Button Lock” section. Is the Sabbath mode set? See the “Sabbath Mode” section. On double-oven models, is one oven self-cleaning? When one oven is self-cleaning, the other oven cannot be set or turned on.
Oven temperature too high or too low	Does the oven temperature calibration need adjustment? See the “Oven Temperature Control” section.
Warm air coming from oven vent	Warm air coming from the oven vent is normal. During a Self-Cleaning cycle, the air stream is increased. The cooling fan may operate both during an oven’s cycle and after the cycle has ended, causing warm air to exit from the oven vent.
Display shows messages	Is the display showing a letter followed by a number? If a letter followed by a number reappears, call for service.
Fan runs during Bake function	It is normal for the convection fan and element to operate during Bake mode to enhance performance and heat distribution.
Long preheat times	Not all cycles require preheating. See cycle instructions for preheat recommendations. Most cycles preheat to 350°F (177°C) in 12 to 18 minutes. Higher temperatures will take more time. Removing unused oven racks prior to preheating can help reduce preheat time.
Self-Cleaning cycle will not operate	Is the oven door open? Close the oven door all the way. Has the function been entered? See the “Self-Cleaning Cycle” section. Has a Delay Start Self-Cleaning cycle been set? See the “Self-Cleaning Cycle” section. On double-oven models, is one oven self-cleaning? When one oven is self-cleaning, the other oven cannot be set to self-clean.
Oven cooking results not what expected	Is the proper temperature set? Double-check the recipe in a reliable cookbook. Is the proper oven temperature calibration set? See the “Oven Temperature Control” section. Was the oven preheated? See the “Baking and Roasting” section. Is the proper bakeware being used? See the “Bakeware” section. Are the racks positioned properly? See the “Positioning Racks and Bakeware” section. Is there proper air circulation around bakeware? See the “Positioning Racks and Bakeware” section. Is the batter evenly distributed in the pan? Check that batter is level in the pan. Is the proper length of time being used? Adjust cooking time. Has the oven door been opened while cooking? Oven peeking releases oven heat and can result in longer cooking times. Are baked items too brown on the bottom? Move rack to higher position in the oven. Are pie crust edges browning early? Use aluminum foil to cover the edge of the crust and/or reduce baking temperature.
Uneven browning of baked items	See the “Positioning Racks and Bakeware” section. Center the baking pan(s) on the rack and allow a minimum of 2" (5 cm) of clearance around all sides of the pan(s). Allow a minimum of 2" (5 cm) of clearance between the oven door and the front edge of baking pans.
Fan gets louder during cooking mode with the door open	If the oven door is opened during a cooking mode and left open for approximately 60 seconds, the cooling fan will switch to a higher speed. You may experience higher noise during this time. When the oven door is closed, the fan will switch back to its lower speed after approximately 60 seconds.

ASSISTANCE OR SERVICE

If you need service

Please refer to the warranty.

If you need replacement parts

If you need to order replacement parts, we recommend that you use only factory specified parts. These factory specified parts will fit right and work right because they are made with the same precision used to build every new JennAir® appliance.

To locate factory specified parts in your area, call us or your nearest JennAir designated service center.

In the U.S.A.

Call the Customer eXperience Center toll-free: **1-800-JENNAIR (1-800-536-6247)**.

Our consultants provide assistance with:

- Features and specifications on our full line of appliances.
- Installation information.
- Use and maintenance procedures.
- Repair parts sales.
- Specialized customer assistance (Spanish speaking, hearing impaired, limited vision, etc.).
- Referrals to local dealers, repair parts distributors and service companies. JennAir designated service technicians are trained to fulfill the product warranty and provide after-warranty service anywhere in the United States.

To locate the JennAir designated service company in your area, you can also look in your telephone directory Yellow Pages.

For further assistance

If you need further assistance, you can write with any questions or concerns at:

JennAir Brand Home Appliances
Customer eXperience Center
553 Benson Road
Benton Harbor, MI 49022-2692

Please include a daytime phone number in your correspondence.

In Canada

Call the JennAir Canada LP Customer eXperience Centre toll-free: **1-800-JENNAIR (1-800-536-6247)**.

Our consultants provide assistance with:

- Use and maintenance procedures.
- Repair parts sales.
- Referrals to local dealers, repair parts distributors and service companies. JennAir designated service technicians are trained to fulfill the product warranty and provide after-warranty service anywhere in Canada.

For further assistance

If you need further assistance, you can write with any questions or concerns at:

JennAir Brand Home Appliances
Customer eXperience Centre
200 - 6750 Century Ave.
Mississauga, ON L5N 0B7

Please include a daytime phone number in your correspondence.

Accessories

To order accessories, visit our website at www.jennair.com.

Affresh® Stainless Steel Cleaning Wipes

(stainless steel models)

Affresh® Stainless Steel Cleaner

(stainless steel models)

Affresh® Kitchen and Appliance Cleaner

27" (68.6 cm) HD Max Capacity Oven Rack

27" (68.6 cm) Sliding Flat Oven Rack

30" (76.2 cm) HD Max Capacity Oven Rack

30" (76.2 cm) Sliding Flat Oven Rack

Porcelain Broiler Pan and Grid

Premium Broiler Pan and Roasting Rack

